

CONFORMS TO S-282-1
A-1496
"CITY OF LA SEWER"

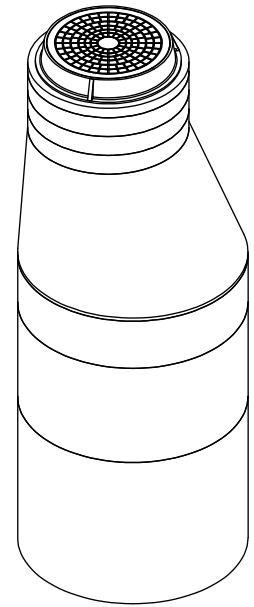
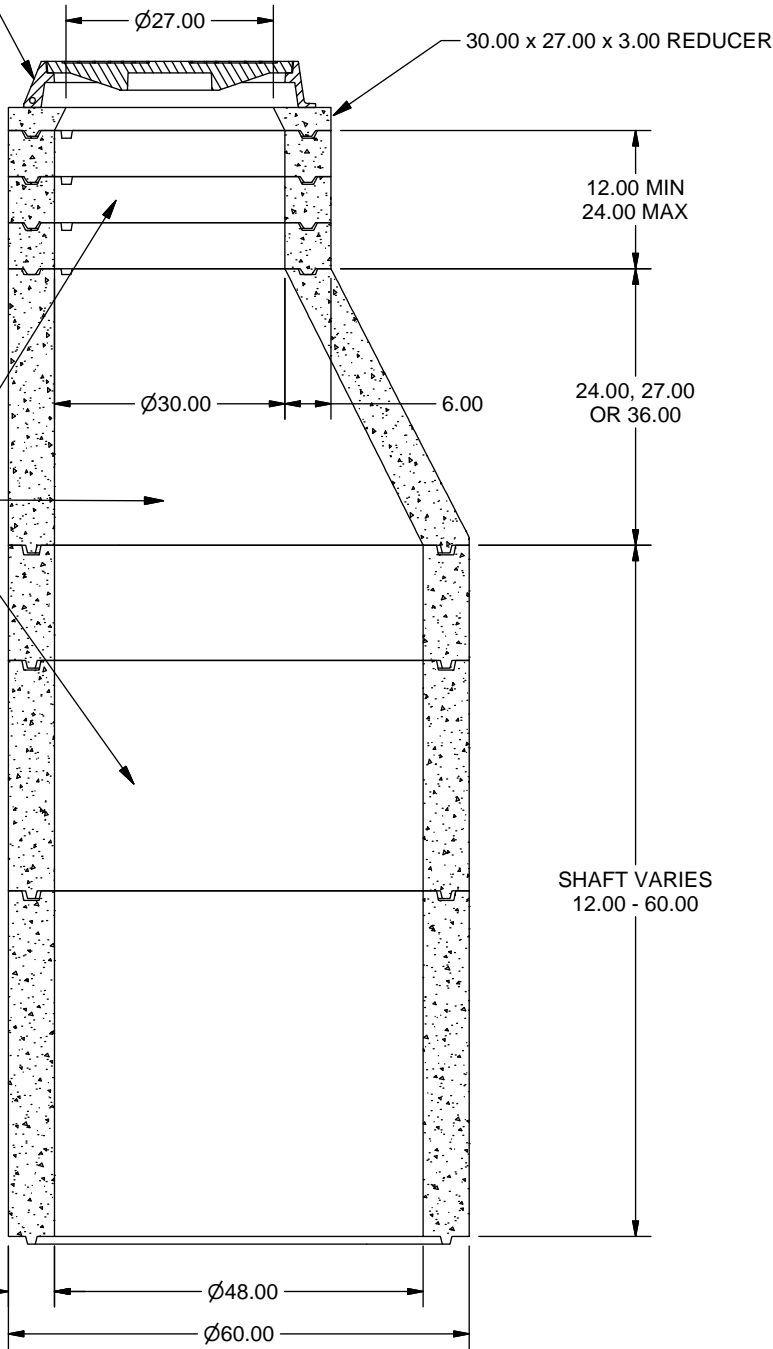

ISOMETRIC VIEW

NOTES: UNLESS OTHERWISE SPECIFIED.

1. ALL DIMENSIONS ARE IN DECIMAL INCHES.
2. PRECAST MATERIALS AND MANUFACTURING METHODS SHALL CONFORM TO ASTM C-478 AND CITY OF LOS ANGELES A STANDARD S-142.
3. CONCRETE SHALL HAVE A MINIMUM COMPRESSIVE STRENGTH F C= 4000 PSI AT 28 DAYS AND CONFORMS TO APMA 600-C-400.
4. THE PORTLAND CEMENT USED IN THE PRECAST SECTIONS SHALL MEET THE REQUIREMENTS OF TYPE II/V HIGH SULFATE RESISTANT CEMENT IN ACCORDANCE WITH ASTM C-150.
5. RING AND COVER SHALL BE GREY CAST IRON CONFORMING TO ASTM A-48 CLASS 35B.
6. RING AND COVER CONFORMS TO S-282-1.
7. INTERIOR OF PRE-CAST MANHOLE SHALL BE LINED WITH AMERON T-LOCK PVC LINER. ALL MATERIAL AND INSTALLATION SHALL BE IN ACCORDANCE WITH MANUFACTURER'S RECOMMENDATIONS.

REGON PRODUCTS			
Phone (805) 527-0841 Fax (805) 584-0769			
TITLE		MANHOLE, 48 DIA, 30 RING & COVER, LA CITY, T-LOCK LINED	
APPROVED BY	DATE	APPROVED BY	DATE
DRAWN BY	DATE	MODEL NO.	SH 1 OF 1
F. ANSALDI	11/16/2005	MH4830	