

STAINLESS STEEL STEP

A-1254 "VCWWD #1 SEWER"

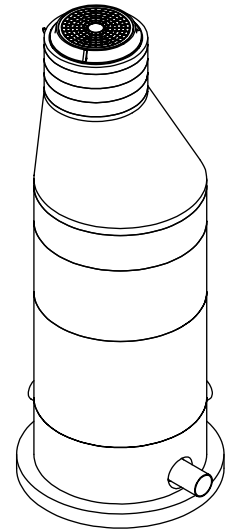
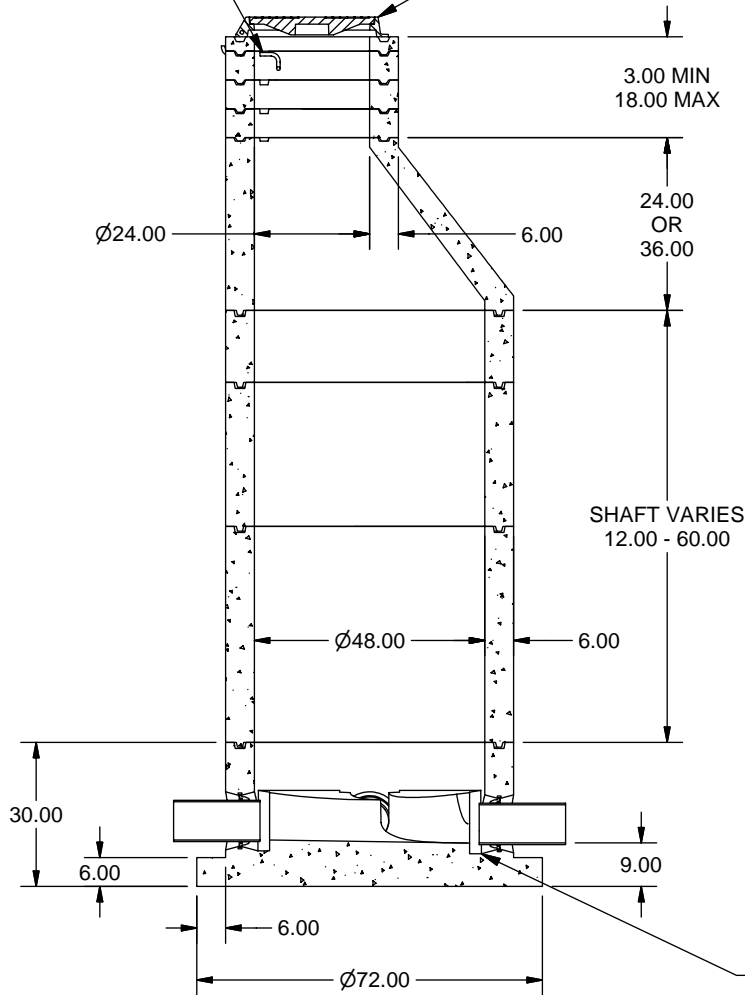

ISOMETRIC VIEW

CONTRACTOR TO FILL ANULAR SPACE AFTER PIPE INSTALLATION.

NOTES: UNLESS OTHERWISE SPECIFIED.

1. ALL DIMENSIONS ARE IN DECIMAL INCHES.
2. PRECAST MATERIALS AND MANUFACTURING METHODS SHALL CONFORM TO ASTM C-478.
3. CONCRETE SHALL HAVE A MINIMUM COMPRESSIVE STRENGTH F_C = 4000 PSI AT 28 DAYS.
4. THE PORTLAND CEMENT USED IN THE PRECAST SECTIONS SHALL MEET THE REQUIREMENTS OF TYPE II/V HIGH SULFATE RESISTANT CEMENT IN ACCORDANCE WITH ASTM C-150.
5. RING AND COVER SHALL BE GREY CAST IRON CONFORMING TO ASTM A-48 CLASS 35B.
6. RING AND COVER A-1254 "VCWWD #1 SEWER".
7. PRE-CAST JOINTS SHALL BE SEALED USING MASTIC.
8. PIPE TO MANHOLE CONNECTIONS SHALL BE MADE USING X-CEL, A-LOK OR Z-LOK FLEXIBLE CONNECTORS BY A-LOK PRODUCTS. CONNECTORS SHALL MEET THE REQUIREMENTS OF ASTM C-923 AND SSPWC 208-6.1.1.



TITLE MANHOLE, 48 DIA, PRECAST BASE, 24 RING & COVER-VEN CO. WATER WORKS DIST. #1

APPROVED BY	DATE	APPROVED BY	DATE	DRAWN BY	DATE	MODEL NO.	SH 1 OF 1
				F. ANSALDI	12/2/2005	MH4824B-VCWWD	