

ADDITIONAL MATERIALS AS REQUIRED TO NEAREST 15°.

PRECAST CHANNEL AS REQUIRED.

A-LOK EXCELL OR Z-LOK GASKETS.

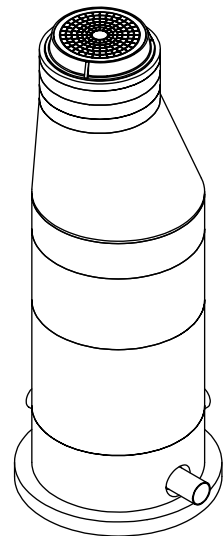
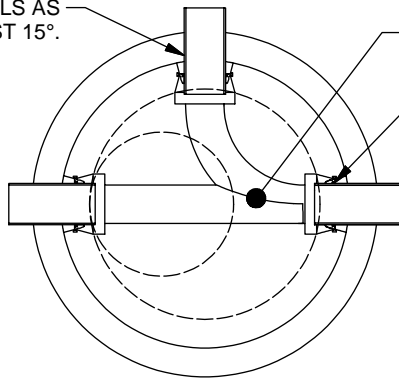

ISOMETRIC VIEW

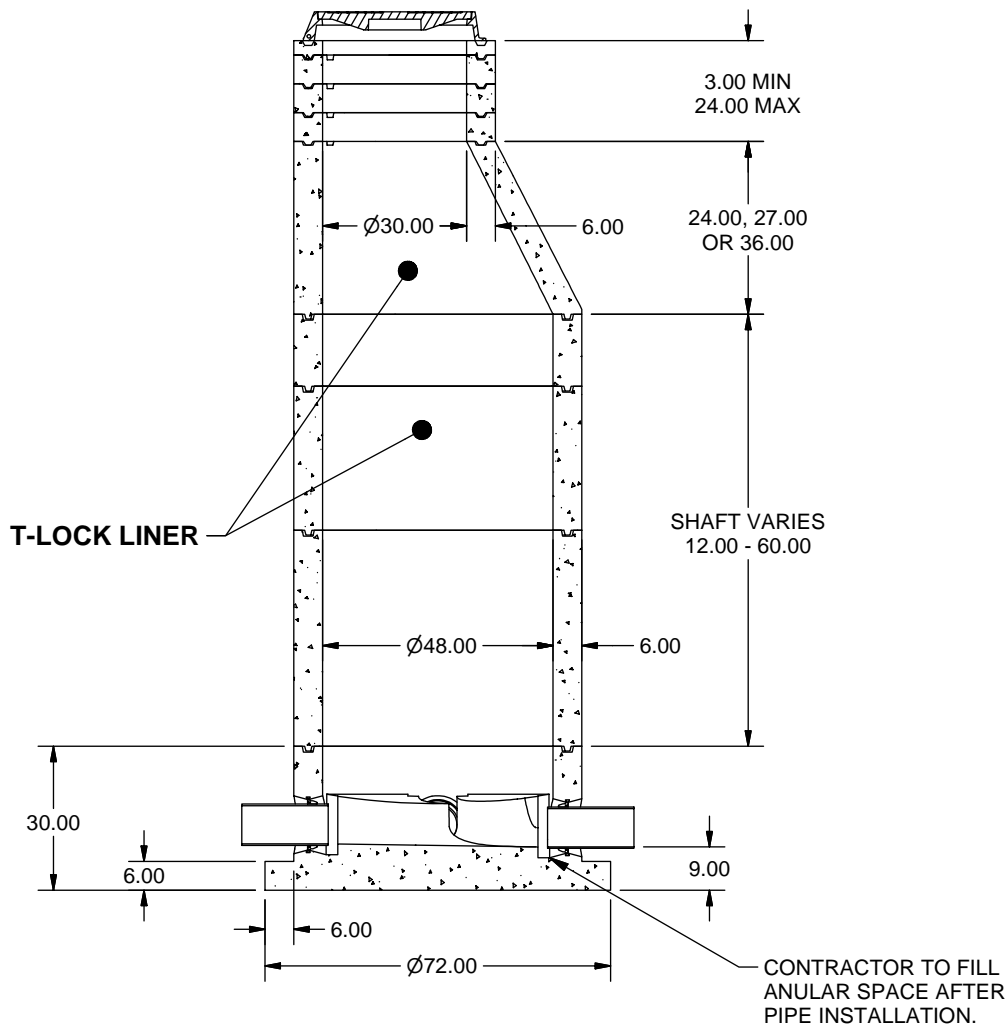

**NOTES:** UNLESS OTHERWISE SPECIFIED.

1. ALL DIMENSIONS ARE IN DECIMAL INCHES.
2. PRECAST MATERIALS AND MANUFACTURING METHODS SHALL CONFORM TO ASTM C-478.
3. CONCRETE SHALL HAVE A MINIMUM COMPRESSIVE STRENGTH F C= 4000 PSI AT 28 DAYS.
4. THE PORTLAND CEMENT USED IN THE PRECAST SECTIONS SHALL MEET THE REQUIREMENTS OF TYPE II/V HIGH SULFATE RESISTANT CEMENT IN ACCORDANCE WITH ASTM C-150.
5. RING AND COVER SHALL BE GREY CAST IRON CONFORMING TO ASTM A-48 CLASS 35B.
6. RING AND COVER STYLE AND MARKINGS VARY BY SPECIFYING AGENCY.
7. PRE-CAST JOINTS SHALL BE SEALED USING A DOUBLE ROW OF RAM-NEK AND WRAPPING THE EXTERIOR OF THE JOINT WITH RUBBER-NEK.
8. PIPE TO MANHOLE CONNECTIONS SHALL BE MADE USING X-CEL, A-LOK OR Z-LOK FLEXIBLE CONNECTORS BY A-LOK PRODUCTS. CONNECTORS SHALL MEET THE REQUIREMENTS OF ASTM C-923 AND SSPWC 208-6.1.1.
9. INTERIOR OF PRE-CAST SHAFTS AND CONE SHALL BE LINED WITH AMERON T-LOCK. ALL MATERIALS AND INSTALLATION SHALL BE IN ACCORDANCE WITH MANUFACTURER'S RECOMMENDATIONS.



Phone (805) 527-0841 Fax (805) 584-0769

TITLE MANHOLE, 48 DIA, PRECAST BASE, 30 RING & COVER, T-LOCK LINED

APPROVED BY	DATE	APPROVED BY	DATE	DRAWN BY	DATE	MODEL NO.	SH 1 OF 1
				F. ANSALDI	11/22/2005	MH4830TB	