

ADDITIONAL MATERIALS AS REQUIRED TO NEAREST 15°.

PRECAST CHANNEL AS REQUIRED.

A-LOK EXCELL OR Z-LOK GASKETS.

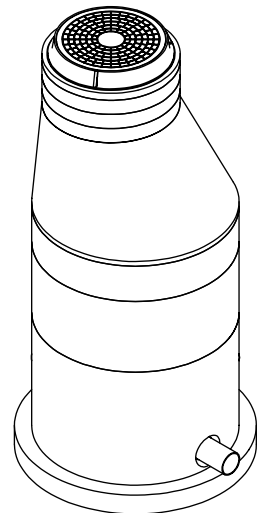
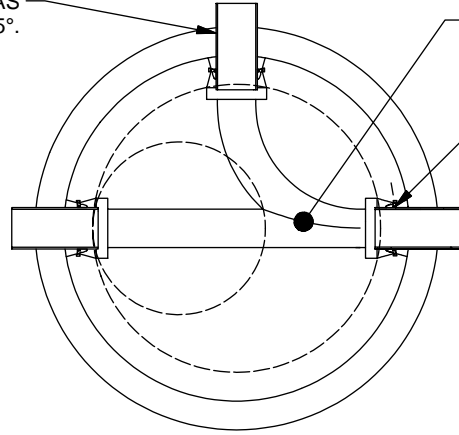

ISOMETRIC VIEW

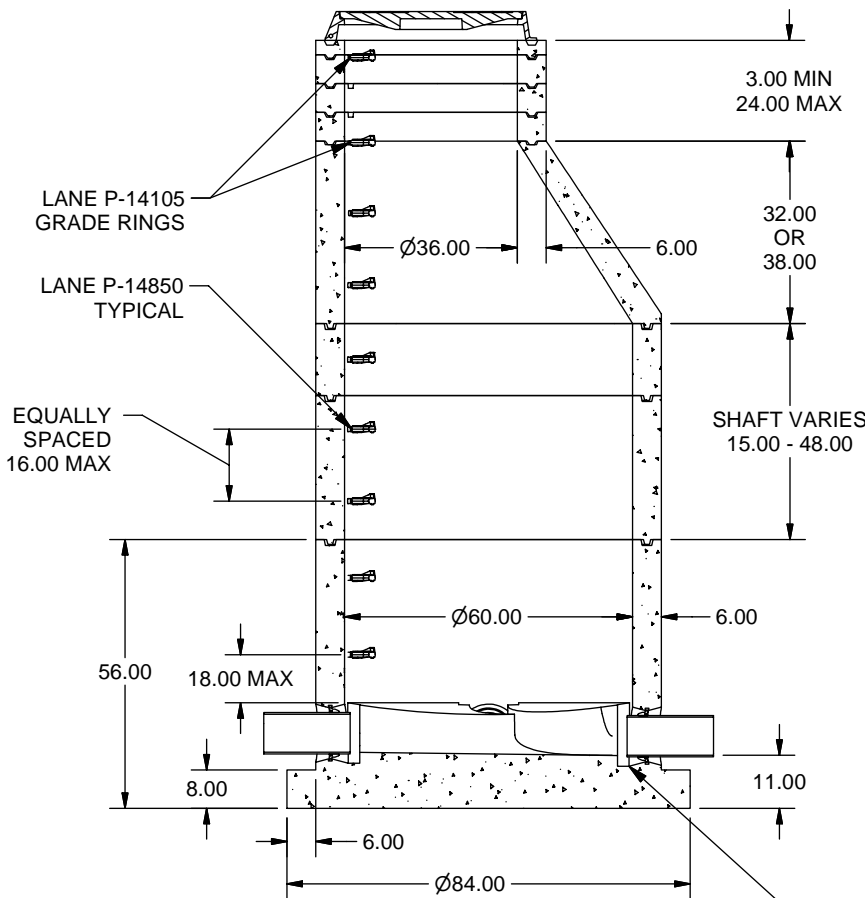

**NOTES:** UNLESS OTHERWISE SPECIFIED.

1. ALL DIMENSIONS ARE IN DECIMAL INCHES.
2. PRECAST MATERIALS AND MANUFACTURING METHODS SHALL CONFORM TO ASTM C-478.
3. CONCRETE SHALL HAVE A MINIMUM COMPRESSIVE STRENGTH F C= 4000 PSI AT 28 DAYS.
4. THE PORTLAND CEMENT USED IN THE PRECAST SECTIONS SHALL MEET THE REQUIREMENTS OF TYPE II/V HIGH SULFATE RESISTANT CEMENT IN ACCORDANCE WITH ASTM C-150.
5. RING AND COVER SHALL BE GREY CAST IRON CONFORMING TO ASTM A-48 CLASS 35B.
6. RING AND COVER STYLE AND MARKINGS VARY BY SPECIFYING AGENCY.
7. STEEL REINFORCED POLYETHYLENE STEPS SHALL CONFORM TO SPPWC AND APWA 636-1.
8. PRE-CAST JOINTS SHALL BE SEALED USING MASTIC.
9. PIPE TO MANHOLE CONNECTIONS SHALL BE MADE USING X-CEL, A-LOK OR Z-LOK FLEXIBLE CONNECTORS BY A-LOK PRODUCTS. CONNECTORS SHALL MEET THE REQUIREMENTS OF ASTM C-923 AND SSPWC 208-6.1.1.

CONTRACTOR TO FILL ANULAR SPACE AFTER PIPE INSTALLATION.



TITLE MANHOLE, 60 DIA, PRECAST BASE, 36 RING & COVER-PLASTIC STEPS

APPROVED BY	DATE	APPROVED BY	DATE	DRAWN BY	DATE	MODEL NO.	SH 1 OF 1
				F. ANSALDI	10/28/2005	MH6036PB	