

48" RCP PIPE DETAIL

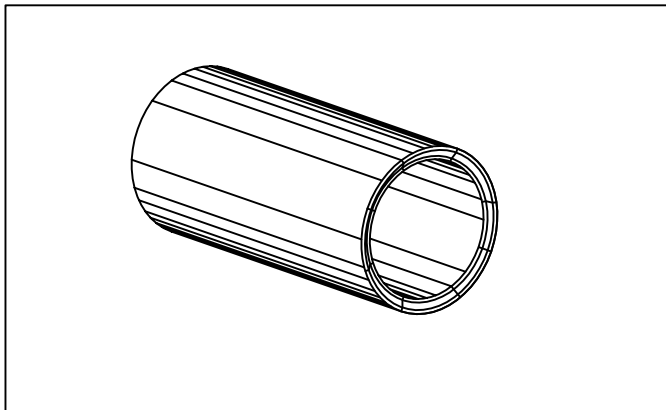

ISOMETRIC VIEW

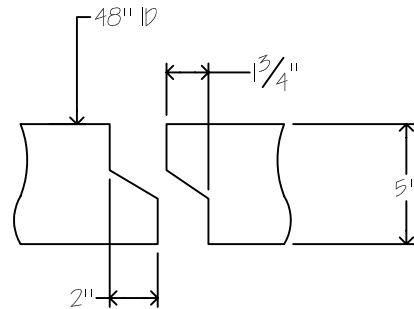

TONGUE AND GROOVE DETAIL

WEIGHTS:
 PER FOOT 867 LBS.
 8' LENGTH 6936 LBS.
 4' LENGTH 3468 LBS.

REVISIONS	BY

NOTES:

- 1) ALL DIMENSIONS SUBJECT TO ALLOWABLE SPECIFICATION TOLERANCES AND PARAMETERS.
- 2) STEEL REINFORCEMENT NOT SHOWN
- 3) PIPE IS MANUFACTURED PER ASTM C-76, AND CONFORMS TO SEC. 207-2 OF STANDARD SPECIFICATIONS FOR PUBLIC WORKS CONSTRUCTION.
- 4) IF USED, INTERNAL RUBBER GASKET SHALL CONFORM TO AASHTO DESIGNATION M-198-75

CONTRACT NO.		PRECOR PRODUCTS
DRAWN BY	FVB	
CHECKED BY		TITLE 48" RCP PIPE DETAIL
DATE	10/30/03	
P/N		SCALE AS SHOWN
SHEET	1 OF	